

**sinclair**  
SERVICE MANUAL

**ZX Printer**

SERVICING MANUAL

FOR

ZX PRINTER

LIST OF CONTENTS

	INTRODUCTION
SECTION 1	GENERAL INFORMATION
SECTION 2	SYSTEM DESCRIPTION
SECTION 3	FAULT DIAGNOSIS AND REPAIR
SECTION 4	REMOVAL AND INSTALLATION PROCEDURES
SECTION 5	ILLUSTRATIONS

LIST OF ILLUSTRATIONS

	Fig No.
Location of Components	1
Location of Components	2
Top Cover and Base Insert Attachment Points	3
Setting-Up Drive Train	4
Pinch Roller Springs	5
Logic Circuit Diagram	6
Circuit Diagram	7

**FOR SERVICE MANUALS  
CONTACT:  
MAURITRON TECHNICAL SERVICES**  
www.mauritron.co.uk  
TEL: 01844 - 351694  
FAX: 01844 - 352554

## SERVICING MANUAL

FOR

ZX PRINTER

### INTRODUCTION

This manual is for use by authorised Sinclair dealers, engineers and representatives as a guide to rectifying faults on the Sinclair ZX Printer. Repair/renewal procedures are limited to those which are specific to this printer; standard procedures for the renewal of electronic components etc., are not included.

NOTE: The printer uses electro-sensitive paper, the grading and quality of which are critical if satisfactory operation of the printer is to be achieved. Only paper which is supplied and approved by Sinclair Research Ltd., or their agents should be used. If adjustments are made in an attempt to make the printer function with other papers, excessive wear of the printer mechanism may result.

## SAFETY MEASURES

1. This instruction manual contains certain  
—— WARNING —— and —— CAUTION ——  
notices which MUST be followed by the user to  
ensure SAFE operation and to retain the  
equipment in a SAFE condition.
  
2. All users of the equipment described in this  
manual MUST have received adequate training  
in its use and application in order to ensure  
SAFE AND PROPER USE.
  
3. Any adjustment, maintenance and repair of the  
opened apparatus under voltage shall be  
carried out only by a skilled person who is  
AWARE OF THE HAZARD INVOLVED.

SECTION 1  
GENERAL INFORMATION

Sub-Section	LIST OF CONTENTS	Page No.
1	Introduction	1.1
2	Principle of Operation	1.1

1. INTRODUCTION

1.1 The ZX Printer is designed for use with the Sinclair range of micro-computers, and provides a permanent record of any computer output which may be displayed on the TV screen. Because of graphic displays always 'join up', long programs, tables of results, elaborate patterns and graphs can be printed out as continuous records, even if carried out in several parts.

2. PRINCIPLE OF OPERATION

2.1 The printing mechanism is unconventional, and consists of two styli which pass successively across the surface of the paper. Each pass represents one row of dots, and six rows of dots form the matrix for a single line of print. A moderately high voltage (50V) is generated in the electronics within the printer, and is routed to a conductor strip in the top cover.

2.2 Each stylus is hairpin-shaped so that one end passes over the surface of the paper whilst the other end contacts the conductor strip, thus carrying the current to the metallic coating of the paper. The return path is through the coating to the conductive rubber roller, which also feeds the paper through the printer, to the earth connections within the electronic circuitry. Before making contact with the paper, the stylus passes over an 'L'-shaped insulating wafer; as the stylus leaves the wafer, it touches the paper and the electrical continuity is sensed by the control electronics which then pulses the applied voltage to provide the printing action.

2.3 A description of the control circuit is given in Section 2.

SECTION 2  
SYSTEM DESCRIPTION

Sub-Section	LIST OF CONTENTS	Page No.
1	Introduction	2.1
2	Top Cover Assembly	2.1
3	Belt and Styli Assembly	2.1
4	Motor and Gear Train Assembly	2.2
5	Control Electronics Board	2.2
6	Base Frame Assembly	2.2
7	Paper Reel Carrier Assembly	2.2
8	Logic Description	2.3
9	Circuit Description	2.3

1. INTRODUCTION

The printer comprises six main assemblies (see Figures 1 and 2):

- (a) Top Cover Assembly,
- (b) Belt Assembly,
- (c) Motor and Gear Train Assembly,
- (d) Control Electronics, Loom and Edge-Connector Assembly,
- (e) Base Frame Assembly,
- (f) Paper Reel Carrier Assembly.

2. TOP COVER ASSEMBLY

- 2.1 The top cover assembly consists of a moulded plastic cover, a metal conductor strip, and a serrated plastic strip which forms a cutting edge to facilitate tearing off the paper printout. Two bushes are moulded into the underside of the cover to house the upper ends of the drive and idler pulley shafts. The assembly is secured to the base frame by four screws which are inserted from the underside of the base (see Figure 3).

3. BELT AND STYLI ASSEMBLY

- 3.1 This assembly comprises an endless, internally-toothed plastic belt to which are attached two hair-pin styli. Each stylus fits over a spigot on the upper edge of the belt, and is retained by a push-on cap. The belt is located on two similar pulleys, one of which is driven by the motor via bevel gearing, while the other is an idler.

#### 4. MOTOR AND GEAR TRAIN ASSEMBLY

4.1 The motor and gear train assembly drives the following:

- (a) belt assembly, which produces the printout image,
- (b) paper feed roller, which moves the paper upwards as printing proceeds,
- (c) encoding disc, which functions in conjunction with the control electronics p.c.board to provide the printout signals to the styli on the belt assembly.

4.2 The horizontally mounted motor drives, via bevel gearing, the vertically mounted pulley and wormshaft which rotates the belt assembly. This wormshaft drives a horizontally mounted wormshaft which, in turn, drives the paper feed roller assembly. At the lower end of the pulley and wormshaft, a spur gear drives the encoder disc, both items being mounted within the underside of the base frame.

#### 5. CONTROL ELECTRONICS BOARD

5.1 The control electronics board is mounted on the upper surface of the base frame. In conjunction with the encoding disc and the LED/photodiode combination, the board provides signals to drive the motor and the printing system. The p.c. board is connected to the double-sided edge-connector by a short loom; the p.c. board-end of the loom is clamped between the top cover and the base frame when the cover is secured to the base.

#### 6. BASE FRAME ASSEMBLY

6.1 The base frame assembly comprises the base frame and the base frame insert, both of which are plastic mouldings. The base frame provides a chassis on which most components are mounted; the base frame insert is a removable section which fits into the underside of the base frame. The insert contains the lower bushes for the shafts of the drive and idler pulleys, as well as the mounting for the LED. It is secured to the base frame by two of the four screws which retain the top cover, and by two shorter screws (see Figure 3).

#### 7. PAPER REEL CARRIER ASSEMBLY

7.1 The paper reel carrier assembly consists of a plastic moulding which houses the reel of electro-sensitive paper, and a spring-loaded pinch roller. The paper is supported in the carrier on two plastic spigotted end-caps which are inserted into the ends of the tube at the centre of the reel; these end-caps should be transferred to the new reel when the reel is changed. The spring-loaded pinch roller forces the paper into contact with the paper feed roller to provide the 'grip' necessary to enable the paper to be fed through the printer. The complete assembly slides into the base frame, and clips into place; it is released by pressure being applied to the point marked PRESS HERE on the underside of the carrier.

- 7.2 Normally, the paper feeds through the printer as printing takes place. However, a manually operated paper feed switch is fitted to enable the paper to be fed through without printing, for example, to provide a tear-off margin at the end of a print-out. The operating button for this switch protrudes through the top cover.

## 8. LOGIC DESCRIPTION

- 8.1 The LED and the photodiode are positioned on opposite sides of an apertured encoder disc. As the disc rotates, the beam of light from the LED is interrupted, thus providing a pulsed signal, the timing of which is governed by the speed of rotation of the disc. This pulsed signal is applied to one input of an AND-gate whose output is connected, via a divide-by-four circuit, to a block input of a buffer store and decoder (see Figure 6).
- 8.2 The buffer store and decoder receives and stores information relating to one line of print, i.e. six scanned lines, from the computer; it responds to clock pulses at its clock input to selectively enable the high-voltage (50V) switch to permit current to flow from the power supply to the conductor strip and thence, via the stylus to the paper. The circuit is earthed via the conducting rubber roller of the paper feed and a resistor. Where the 50V is applied to the surface of the paper, the metallic coating is burned off, leaving the dark undercoating exposed to provide the permanent image. The conductor strip is also connected to the paper detect circuit which detects when the stylus has run off the edge of the insulating wafer and has commenced tracking across the surface of the paper.
- 8.3 The encoder disc produces 1024 pulses across the printing width of the paper; these are produced to 256 by the divide-by-four circuit to ensure that the register of each line of dots within the matrix is maintained to within a quarter of the width of a dot.

## 9. CIRCUIT DESCRIPTION

- 9.1 TR1 and TR2 form a self regulating 50V power supply. The 50V may be measured conveniently on C4 (see Figure 7).
- 9.2 When the stylus first makes contact with the paper at the left hand margin, TR5 is switched on via R8. This raises the level at pin 4 of the ULA and results in the encoder signal being passed to the associated micro computer. C6 and R11 prevent contact being lost momentarily and are critical in value. Many problems have been experienced with devices giving too much gain and TR5 which on some early printers was a ZTX550 should be replaced by a ZTX551.
- 9.3 TR3 and TR4 switch the 50V to the stylus in order to generate printing.



- 9.4 The phototransistor TR9 is soldered to the board, while the LED is on flying leads stuck into the base insert. These items are subject to a lot of tolerances but there should be greater than 200 mV p-p at pin 2 of the ULA when operating. Common faults encountered include, over-etched encoder disc, encoder disc working loose, incorrectly formed slot in the base frame in front of the phototransistor (some have metal shims with photo-etched slots). Dirt in the encoder disc or in front of the phototransistor also give misleading results. The operation of transistor TR9 can be readily checked using an oscilloscope probe on the emitter.
- 9.5 Transistor TR6 switches the motor on and off. During the last two lines of an 'L print' the motor runs slowly; this is accomplished by switching TR6 on and off, using the time constant R13/C8 in conjunction with the phototransistor output.
- 9.6 The motor is fitted internally with a varistor ring suppressor. Without this it would generate so much interference to make it unusable. It is unlikely, however, that this would occur.

FOR SERVICE MANUALS  
CONTACT:  
**MAURITRON TECHNICAL SERVICES**  
[www.mauritron.co.uk](http://www.mauritron.co.uk)  
TEL: 01844 - 351694  
FAX: 01844 - 352554

### SECTION 3

#### FAULT DIAGNOSIS AND REPAIR

The following table is intended as a general guide to the diagnosis and rectification of most of the faults which may occur after considerable usage of the printer.

FAULT	POSSIBLE CAUSE	REMEDY
<p>1. Poor print quality:</p> <p>(a) Vertical zig-zag usually worse on right-hand side.</p> <p>(b) Horizontal lines unevenly spaced.</p> <p>(c) Print fading out over part of line</p> <p>(d) 'Noisy' printing.</p>	<p>(a) Worn belt.</p> <p>(b) Worn belt.</p> <p>(c) Dirt on conductor strip in top cover.</p> <p>(d) (i) Excessive gain on TR5. (ii) Insufficient signal from encoder.</p>	<p>(a) Fit new belt.</p> <p>(b) Fit new belt.</p> <p>(c) Clean and lubricate conductor strip - use Electrolube.</p> <p>(d) (i) Fit ZTX551 in place of ZTX550 (ii) Fit new ULA.</p>
<p>2. No print:</p>	<p>(a) If print is all black, check TR4.</p> <p>(b) If no image, check that white wire is connected to conductor strip.</p> <p>(c) Dirt on photodiode and/or LED.</p> <p>(d) Defective photodiode and/or LED.</p>	<p>(a) If defective, change TR4.</p> <p>(b) Connect white wire to conductor strip and check 50V is present on strip.</p> <p>(c) Clean photodiode and/or LED.</p> <p>(d) Fit new photodiode and/or LED.</p>

FAULT	POSSIBLE CAUSE	REMEDY
3. Motor not operating:	(a) Conductor strip has become loose in top cover. (b) Motor bevel pinion touching motor mounting screws.	(a) Fit new top cover assembly. (b) Check tightness of screws and reset gear mesh (see Figure 4).
4. Motor running slowly:	(a) Excessive friction on encoder disc. (b) Excessive gain on TR5	(a) Slightly slacken base insert screw near encoder disc. (b) Fit ZTX551 in place of ZTX550.
5. Inadequate paper feed:	(a) Insufficient spring pressure on paper pinch roller. (b) Paper reel ends jammed against the cover.	(a) Fit new 0.60 mm dia. springs. (b) Ensure that reel is wound tightly and not touching cover.

FOR SERVICE MANUALS  
 CONTACT:  
**MAURITRON TECHNICAL SERVICES**  
[www.mauritron.co.uk](http://www.mauritron.co.uk)  
 TEL: 01844 - 351694  
 FAX: 01844 - 352554

SECTION 4  
REMOVAL AND INSTALLATION PROCEDURES

Sub-Section	LIST OF CONTENTS	Page No.
1	Cleaning and Lubrication	4.1
2	Top Cover Assembly	4.1
3	Belt and Styli Assembly	4.2
4	Motor and Gear Train Assembly	4.3
5	PC Board, Loom and Edge Connector Assembly	4.4
6	Encoder Disc	4.5
7	Paper Feed Roller Assembly	4.6
8	Paper Reel Carrier Pinch Roller Springs	4.7

1. CLEANING AND LUBRICATION

- 1.1 A certain amount of dust from the metallized coating of the paper will accumulate within the printer as printing proceeds. Whenever the printer is dismantled for any reason, the dust should be removed, using a gentle airblast and/or a soft brush.

————— CAUTION —————

Never use solvents or other fluids as they may attack the plastic or rubber components

- 1.2 Before re-assembly of the printer, bushes should be lightly lubricated with Molycote 44, but gears, wormshafts etc., must not be lubricated; a thin coating of electrolube should be applied to the conductor strip in the top cover assembly.

2. TOP COVER ASSEMBLY

- 2.1 To remove the top cover assembly:
- (a) Remove the paper reel carrier assembly.
  - (b) Remove the four screws at the corners of the base (see Figure 3).
  - (c) Lift the cover approximately 15 mm, remove the white wire connector from the spade terminal on the conductor strip in the underside of the cover.
  - (d) Withdraw the cover, and lift off the operating button for the button feed switch.

- (e) If the serrated tear-strip is worn or damaged, this can be removed by pushing out the centre lug (near the spade terminal), lifting the outer edges of the tear-strip and moving it away from the cover to disengage the retaining lugs from the slots in the cover.

## 2.2 To install the top cover assembly:

- (a) If a new tear-strip is to be fitted, insert its retaining lugs into the slots in the top cover, and push down on the tear-strip until it clips into position; ensure that the centre lug is engaged in its slot in the cover.
- (b) Position the belt assembly on its pulleys so that the styli are at the extreme left and right of the printer, that is, they are on the pulleys. Ensure that the styli are in the trailing position - the belt rotates clockwise, viewed from the top.
- (c) Place the operating button on the spigot of the paper feed switch, and ensure that the sloping face of the button is correctly aligned with the contour of the top cover.
- (d) Place the top cover in position, and connect the white wire to the spade terminal on the conductor strip.
- (e) Gently manoeuvre the top cover into position, ensuring that both pulley shafts engage their locating bushes, and that the paper feed switch operating button locates correctly on the cut-out in the top cover. Check that the wires to the switch are not caught between the cover and the base frame.

NOTE: Care is needed to avoid damage to the insulator strip on the vertical web of the base frame.

- (f) Secure the top cover to the base frame with the four screws.
- (g) Fit the paper reel carrier assembly.

## 3. BELT AND STYLI ASSEMBLY

### 3.1 To remove the belt and styli assembly:

- (a) Remove top cover assembly (see para 2.1).
- (b) Lift off the belt and styli assembly from the pulleys.
- (c) If it is desired to remove a stylus, pull off the stylus retaining cap, and lift the stylus from its mounting spigot on the belt.

3.2 To install the belt and styli assembly:

- (a) If a stylus has been removed, place a new stylus over its mounting spigot on the belt so that the leg of the stylus which has the longer 'foot' is outside the belt; secure the stylus by pushing the retainer cap on to the spigot.
- (b) Place the belt assembly over the pulleys so that the styli are at the outer edges of the pulleys, and the styli are in the trailing position on the belt - the belt rotates in a clockwise direction, viewed from the top.
- (c) Install the top cover assembly (see para 2.2).

4. MOTOR AND GEAR TRAIN ASSEMBLY

4.1 To remove motor and gear train assembly:

- (a) Remove top cover assembly (see para 2.1).
- (b) Remove belt and styli assembly and idler pulley (see para 3.1).
- (c) Remove the drive pulley by pulling it upwards (its shaft is a push fit in the large spur gear within the base frame).
- (d) Prise the wormshaft out of its supports, and remove it.
- (e) Prise the bevel pinion from the motor shaft, and remove the spacer from the shaft (if fitted).
- (f) Unsolder the wires from the motor terminals.
- (g) Remove the two screws securing the motor to its mounting, and withdraw the motor.

NOTE: On earlier printers, the motor is lightly glued to its mounting, and it will be necessary to prise them apart carefully.

4.2 To install motor and gear train assembly:

Prior to installing the motor, determine whether the base frame is of the early pattern or the later design. On the early pattern, there is a cross-shaped slot in the motor mounting flange; the later design has a vertical slot only.

- (a) If the printer is of the early type, apply a thin coat of suitable glue, such as Loctite, to the face of the motor.

- (b) Position the motor on its mounting flange with the orientation mark (on the terminal end of the motor) at the outside, and insert the two attachment screws. If the printer is of the later design, the screws may be tightened fully at this stage. If the printer is of the earlier pattern, the vertical height of the motor must be set as shown in Figure 4; it may be advantageous to manufacture the jig shown in Figure 4 to ensure accurate setting of the motor before the screws are tightened.
- (c) Fit the spacer to the motor shaft, and push the bevel pinion fully on to the shaft.

NOTE: On some motors, the end bearing is recessed on its outer face. The spacer for use with this motor is 3.25 mm long, whereas the spacer for use with the flush-faced end bearing is 2.92 mm long. It is essential to ensure that the correct spacer is fitted.

If a spacer is not available, set the bevel pinion clearance as shown in Figure 4.

- (d) Solder the wires to the motor terminals - the red wire connects to the outer terminal, the black wire to the inner terminal. Ensure that capacitor C9 is connected across the motor terminals.

NOTE: The black wire must pass **over** the white wire which connects to the conductor strip in the top cover.

- (e) Lightly lubricate the ends of the wormshaft with Molycote 44, and press the shaft into its support bushes.
- (f) Support the base insert in the vicinity of the large spur gear, and push the drive pulley shaft fully home into the spur gear boss which protrudes upwards through the base frame.
- (g) Fit the idler pulley and belt assembly.
- (h) Fit the top cover assembly (see para 2.2).

## 5. PC BOARD, LOOM AND EDGE CONNECTOR

5.1 To remove the p.c.board, loom and edge-connector assembly:

- (a) Remove the top cover assembly (see para 2.1).
- (b) Remove the motor (see para 4.1).
- (c) Disconnect the green wire at the earth terminal.
- (d) Remove the two screws securing the base insert, and ease it clear of the base frame. Carefully ease the LED and its leads out of the mounting clips on the base insert, and remove the insert.

- (e) Remove the two screws securing the p.c.board to the base frame.
- (f) Gently ease the photodiode and its leads out of the mounting clips on the base frame, and remove the p.c.board, loom, and edge-connector assembly - take care to avoid damage to the LED, photodiode and their leads.

5.2 To install p.c.board, loom and edge-connector assembly:

- (a) Carefully position the p.c.board on the base frame, with the LED and its leads passing through the cut-out in the base frame.
- (b) Clip the photodiode and its leads into place on the base frame (ensuring that the lens is facing downwards), and secure the p.c.board to the base frame with its two screws.
- (c) Carefully insert the LED and its leads into the clips on the base insert, ensuring that the lens faces upwards.
- (d) Secure the base insert to the base frame with its two screws.
- (e) Connect the green wire to the earth terminal.
- (f) Install the motor (see para 4.2).
- (g) Install the top cover assembly (see para 2.2).

## 6. ENCODER DISC

6.1 To remove the encoder disc:

- (a) Remove the screws securing the base insert, and ease the insert out of the base frame.

NOTE: Avoid damaging the LED and its leads which are clipped to the base insert.

- (b) Carefully lift the edge of the encoder disc until its spindle is clear of the bush in the base frame, and slide the disc clear. It is not necessary to remove the large spur gear which drives the encoder disc.

6.2 To install the encoder disc:

- (a) Apply a trace of Molycote 44 to the bush for the encoder disc spindle.



- (b) Ensure that the encoder disc is clean, and carefully slide its edge under the large spur gear until the spindle can be seated in its bush.

NOTE: Later versions of the printer have a modified spur gear on the encoder disc and a flat spring fitted to the spindle, above the spur gear. These versions are identified by the pale blue colour of the small spur gear (the earlier versions are white). This modified gear and flat spring can only be fitted to the later version of the base insert - they must NOT be fitted to the earlier versions.

- (c) Carefully fit the base insert into the base frame, and secure it with its screws; avoid damage to the LED and its leads.

FOR SERVICE MANUALS  
CONTACT:

**MAURITRON TECHNICAL SERVICES**

[www.mauritron.co.uk](http://www.mauritron.co.uk)

TEL: 01844 - 351604

FAX: 01844 - 352554

## 7. PAPER FEED ROLLER ASSEMBLY

### 7.1 To remove the paper feed roller assembly:

- (a) Remove the top cover assembly (see para 2.1).
- (b) Disconnect the green wire from the earth terminal.
- (c) Remove the screw, washer and nut which secure the earth terminal to the base frame, and withdraw the terminal.
- (d) Slide the paper feed roller assembly sideways until its end disengages from its worm wheel, and withdraw the roller assembly.

### 7.2 To install the paper feed roller assembly:

- (a) Insert the round end of the paper feed roller assembly into its mounting in the base frame.
- (b) Slide the square end of the roller assembly into the worm wheel, and push it fully home.
- (c) Secure the earth terminal to the base frame with the screw, washer and nut, and ensure that the terminal contacts the end of the roller spindle.
- (d) Connect the green wire to the earth terminal.
- (e) Install the top cover assembly (see para 2.2).

8. PAPER REEL CARRIER PINCH ROLLER SPRINGS

A spring is fitted at each end of the paper reel carrier to force the pinch roller into contact with the paper. Although the springs are identical, they must be fitted in the correct manner (see Figure 5) - always remove and install one spring at a time. Early printers are fitted with springs made from 0.55 mm diameter wire; later printers are fitted with springs made from 0.60 mm diameter wire. Whenever these springs are to be changed, the thicker springs should be fitted, regardless of whether the printer is an early or later version.

FOR SERVICE MANUALS  
CONTACT:  
**MAURITRON TECHNICAL SERVICES**  
[www.mauritron.co.uk](http://www.mauritron.co.uk)  
TEL: 01844 - 351694  
FAX: 01844 - 352554

SECTION 5  
ILLUSTRATIONS

LIST OF CONTENTS

Fig No.

---

Location of Components (1)	1
Location of Components (2)	2
Top Cover and Base Insert Attachment Points	3
Setting Up Drive (Gear) Train	4
Pinch Roller Springs	5
Logic Circuit Diagram	6
Circuit Diagram	7

---

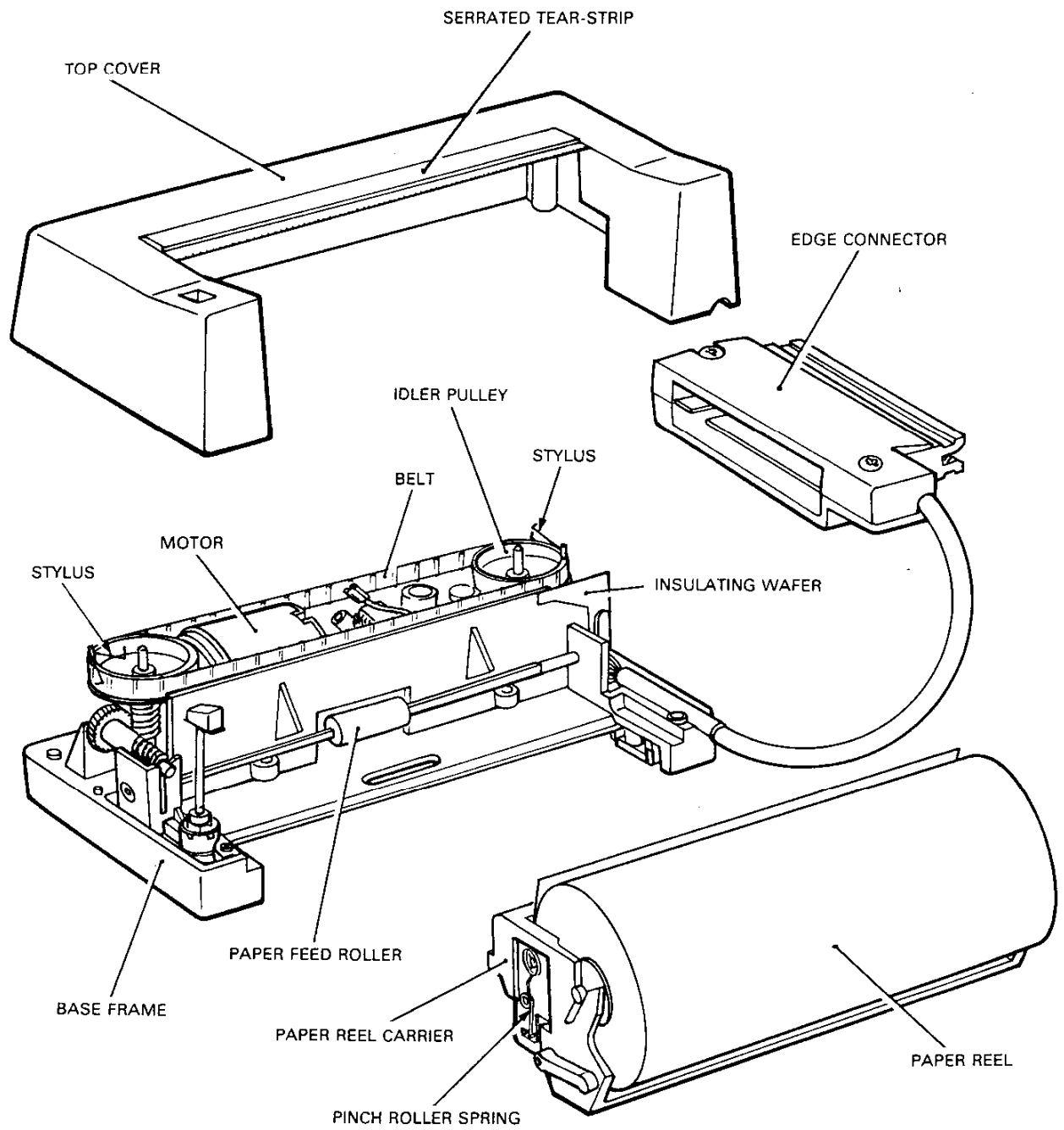

FIGURE 1 LOCATION OF COMPONENTS (1)

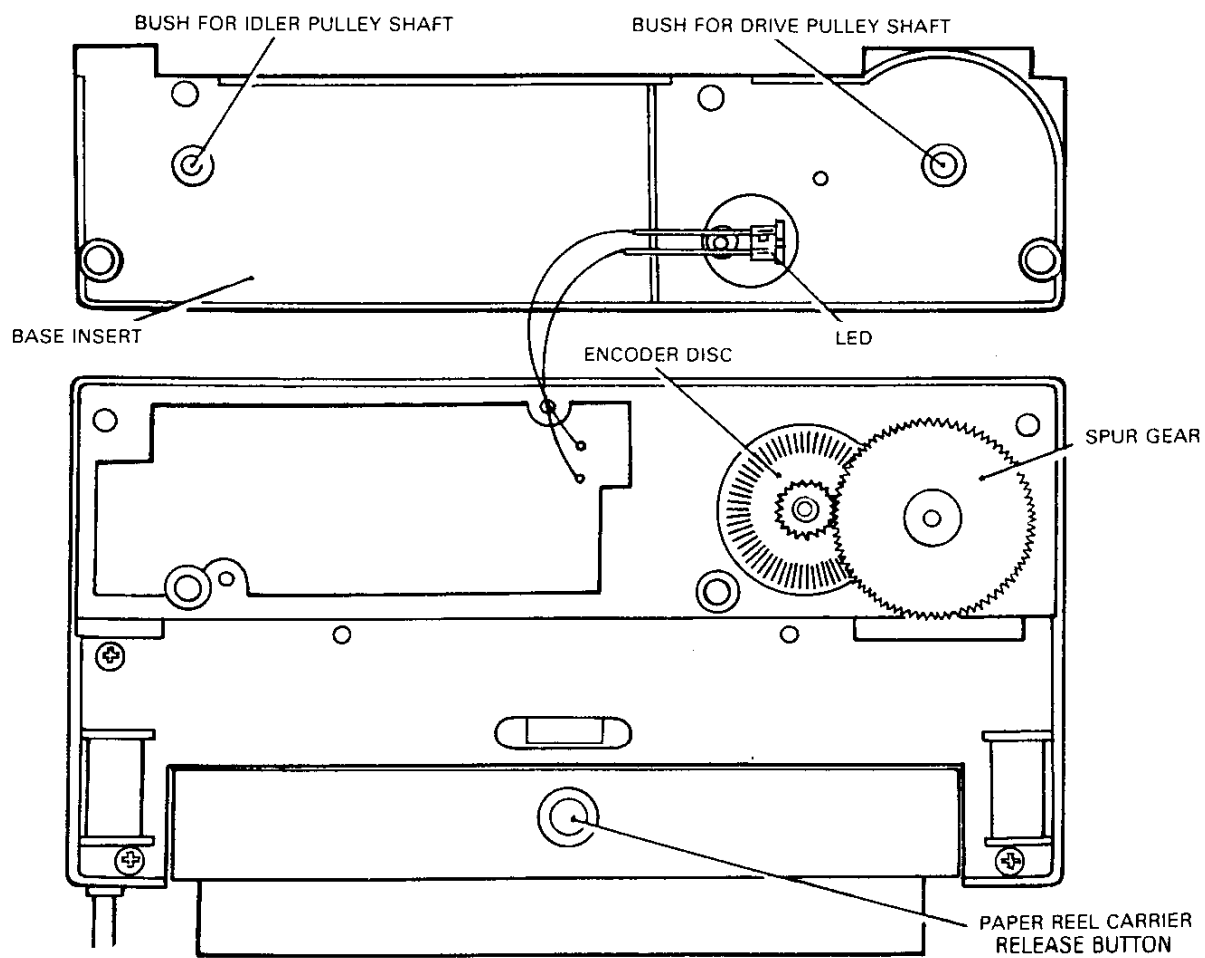
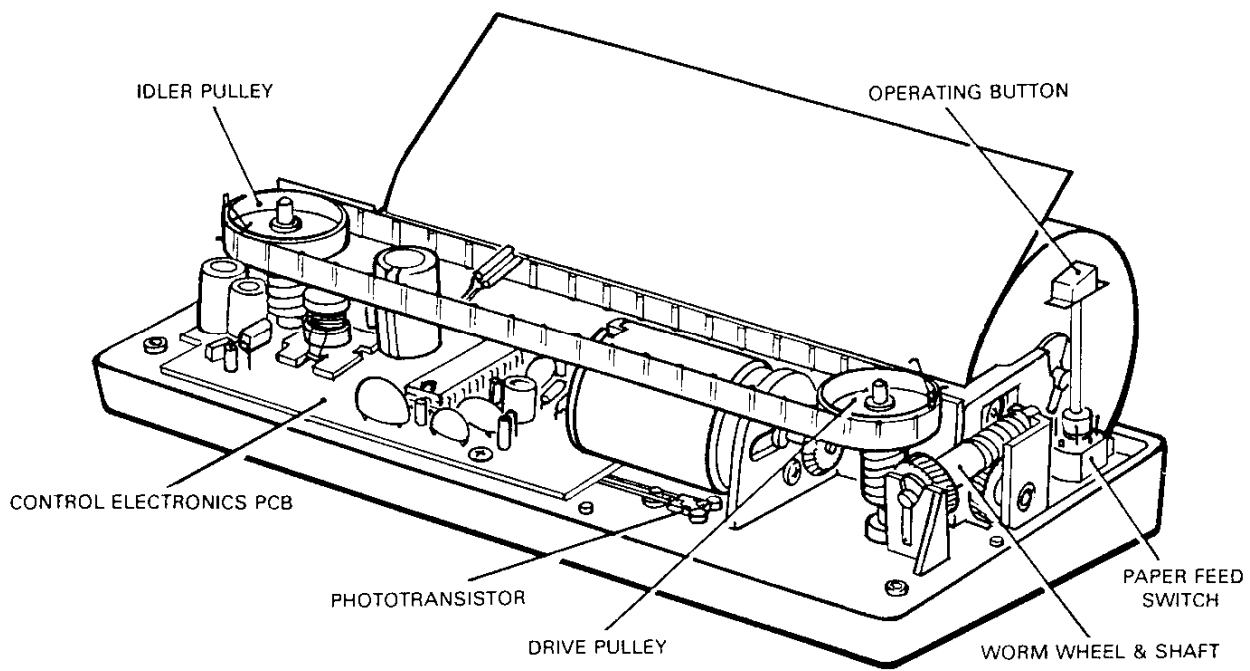

FIGURE 2 LOCATION OF COMPONENTS (2)

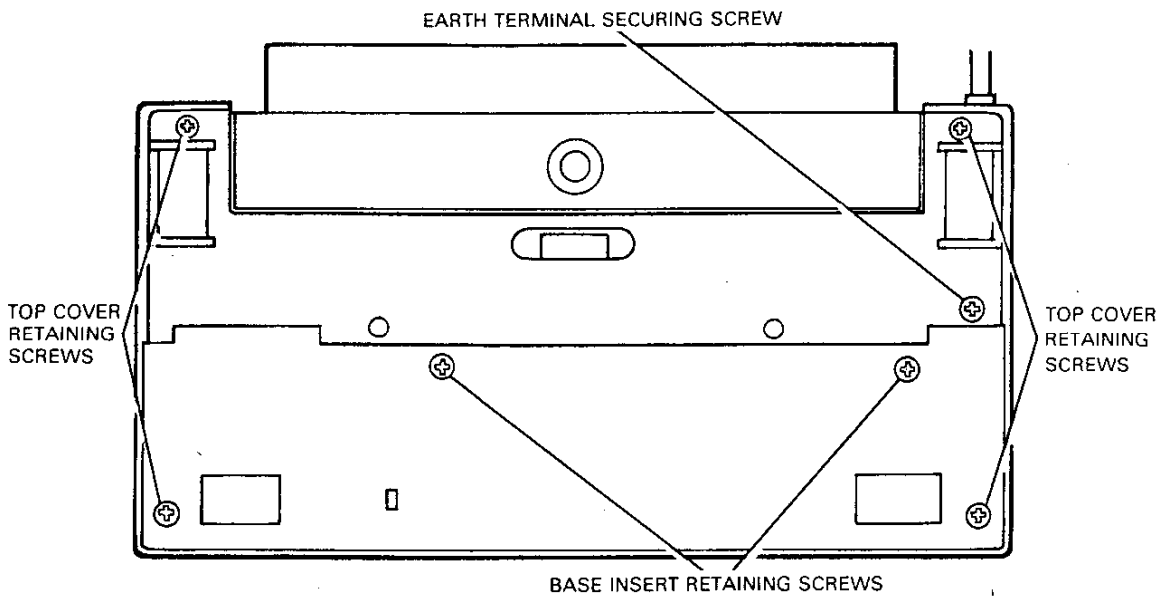

FIGURE 3 TOP COVER & BASE INSERT ATTACHMENT POINTS

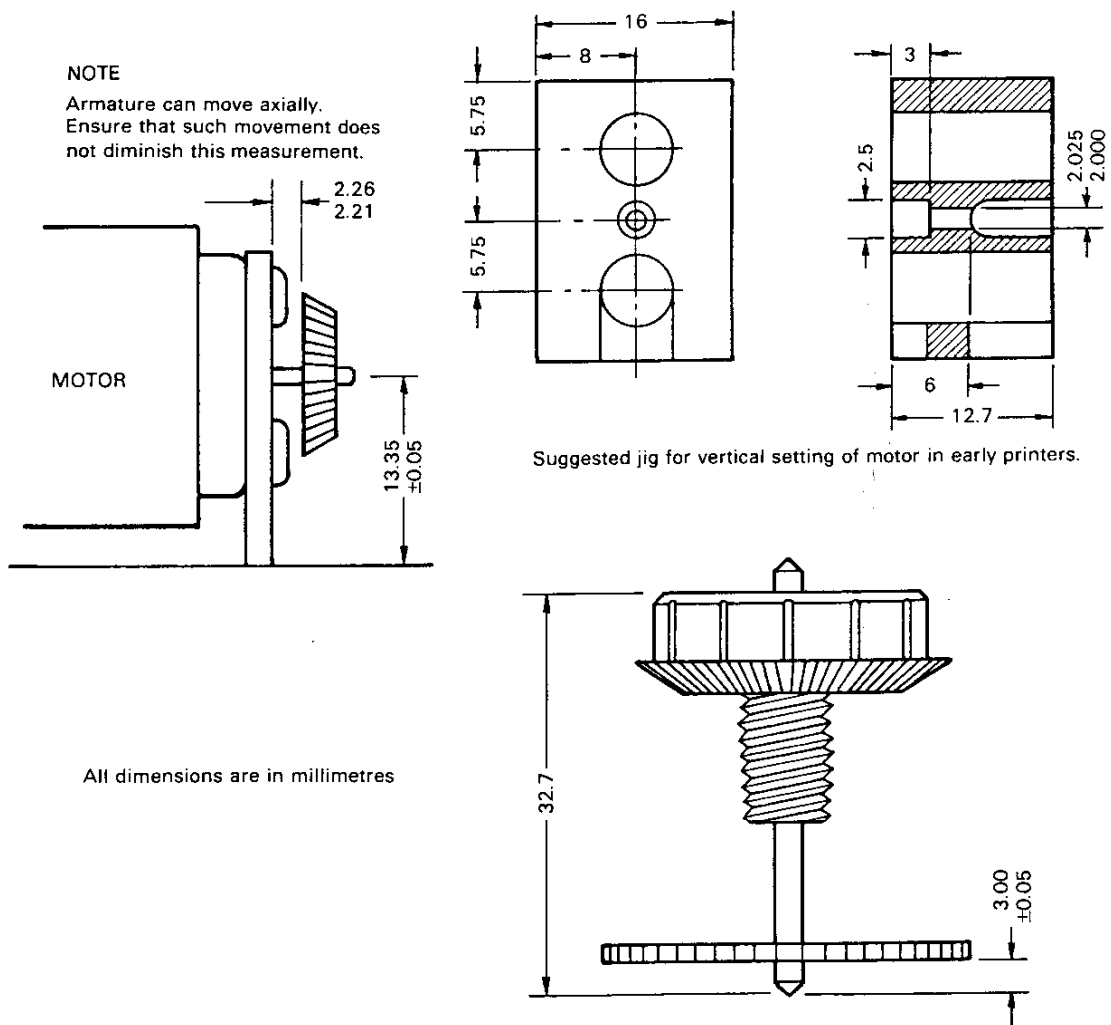
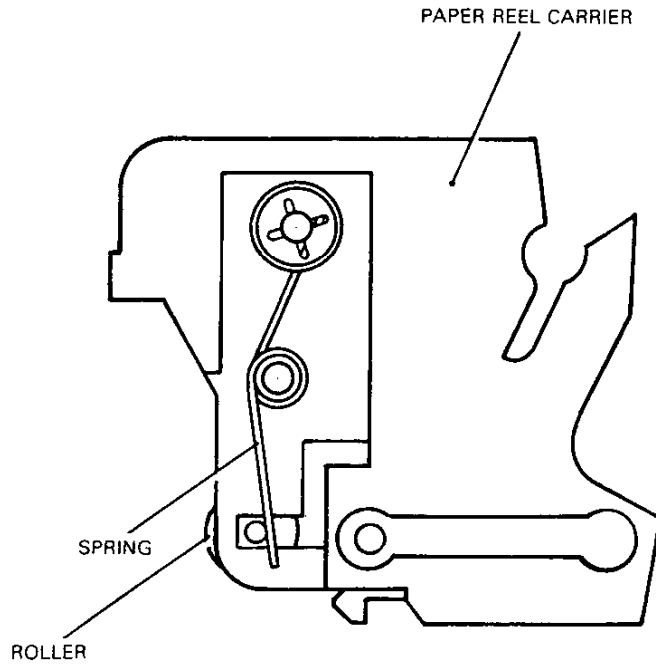

FIGURE 4 SETTING-UP DRIVE TRAIN



FOR SERVICE MANUALS  
 CONTACT:  
**MAURITRON TECHNICAL SERVICES**  
[www.mauritron.co.uk](http://www.mauritron.co.uk)  
 TEL: 01844 - 351694  
 FAX: 01844 - 352554

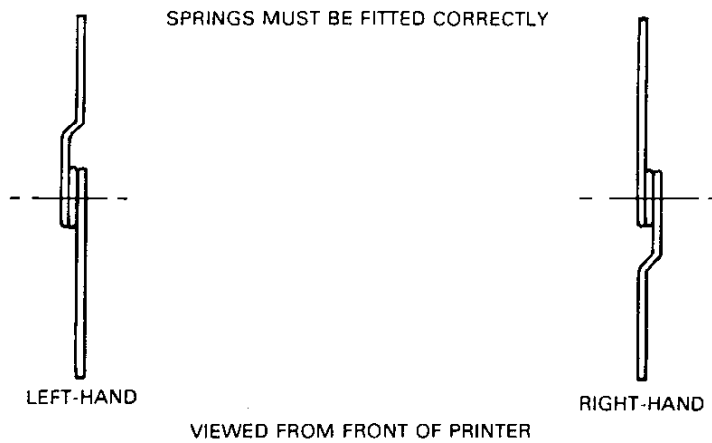

FIGURE 5 PINCH ROLLER SPRINGS

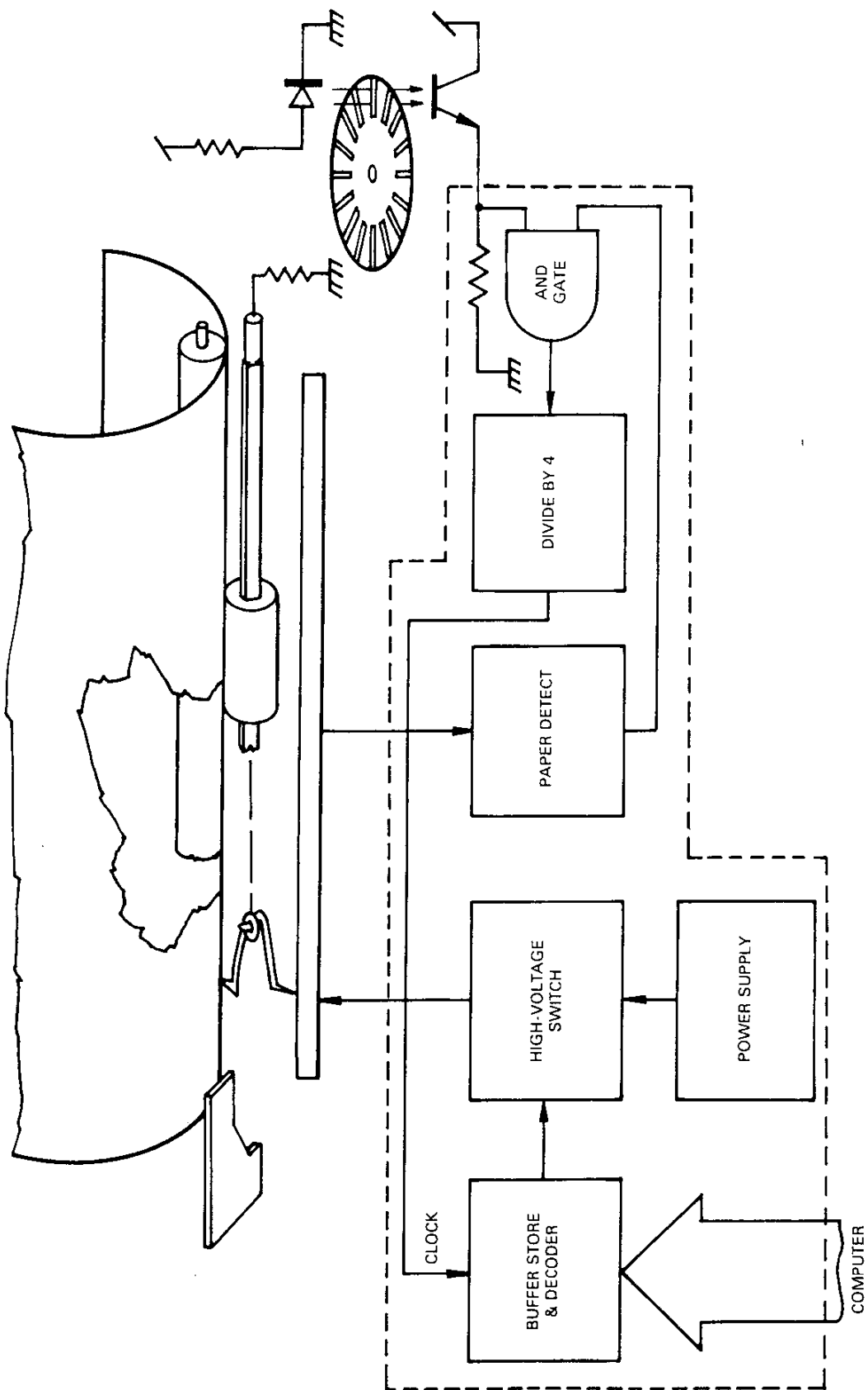

FIGURE 6 LOGIC CIRCUIT DIAGRAM



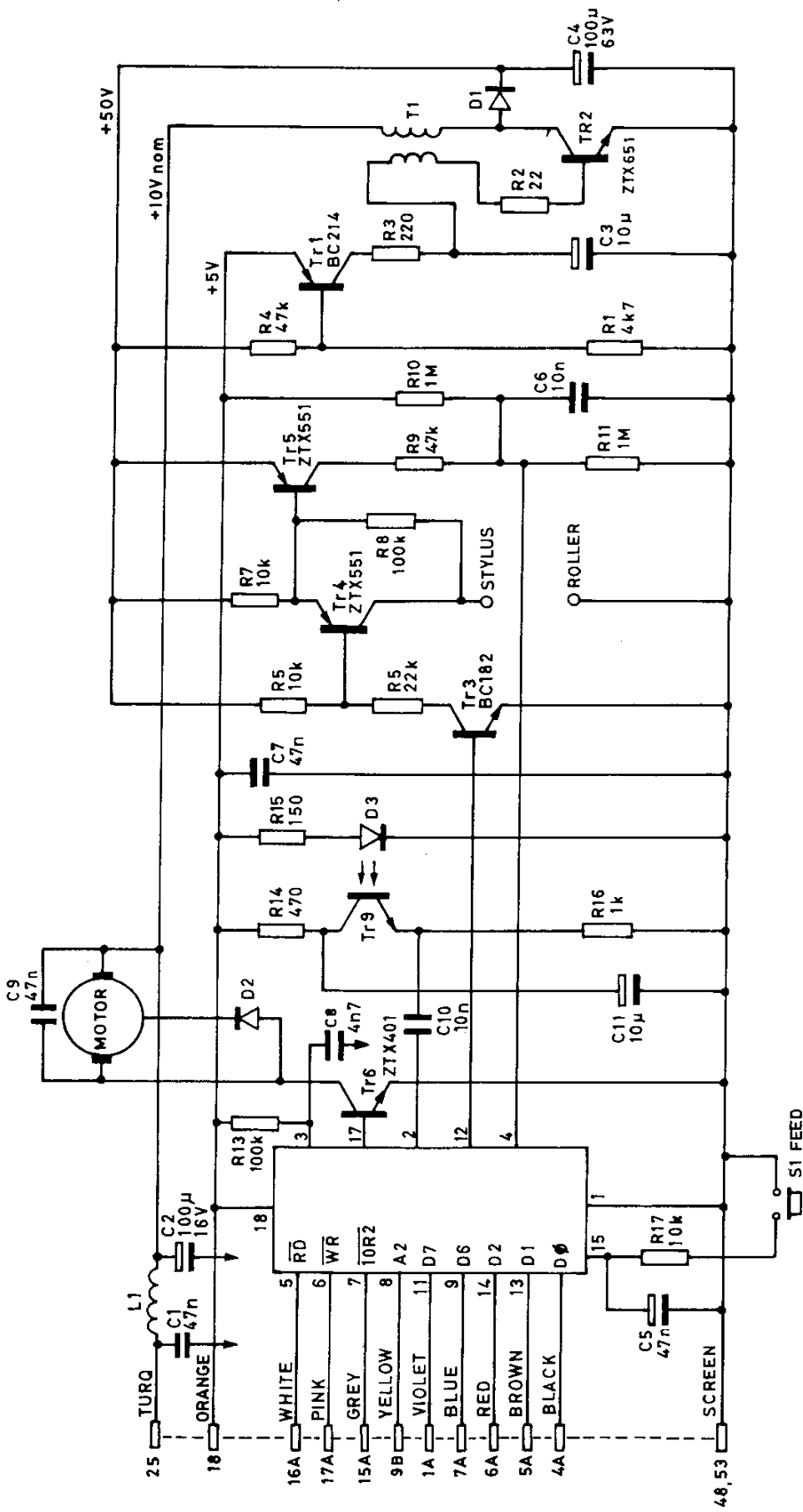

FIGURE 7 CIRCUIT DIAGRAM